



Throttle/Isolation Valves
47200 Series

Throttle/Isolation

TIV Throttle / Isolation Valve

Introduction	Page 110
Specifications	Page 111
Theory of Operation	Page 112
100-mm 4.0-inch	Page 113
150-mm 6.0-inch	Page 114
200-mm 8.0-inch	Page 115
250-mm 10.0-inch	Page 116
300-mm 12.0-inch	Page 117
350-mm 14.0-inch	Page 118

TVC Throttle Valve Controller

Introduction	Page 119
Specifications	Page 120
TVC-2000-2	Page 121





Product Features

- Body constructed from 304 stainless steel
- Throttle vanes constructed from vacuum compatible aluminum
- Gate seals against atmosphere in both directions
- Gate and actuator mechanism serviceable without removing the valve body from system
- Welded bellows shaft seal

Description

The 47200 Series Throttle/Isolation Gate Valve is a unique concept incorporating throttling and isolation in the same valve. Constructed of 304 stainless steel with vacuum compatible aluminum vanes, the valve has two welded bellows to seal both actuators for gate isolation and throttling vanes. With a low profile actuator, this valve lends itself to installation in limited space locations. The result is a high cycle-life valve with minimal loss of process gases. The valve features a stepper motor controlled Throttling Vane System. The Throttle Valve Controller, sold separately, may be used for precise pressure control.

Maintenance of the valve, including gate seal replacement, is achieved by removing the actuator and gate assembly from the valve body. It is not necessary to remove the valve body from its installed system mounting in order to access serviceable parts.

Available in a range of standard sizes from 4-inch to 14-inch ID. Prices available on request.

Applications

Various vacuum processes call for the introduction of gases during the procedure. In other vacuum processes, gases may be produced as a by-product of the process. The introduction of gases and the presence of a vacuum pump are seemingly working against each other. In fact, a high vacuum pump would remove as much gas from a chamber as possible.

Since process gases are expensive, it would be best to minimize the evacuation of the gas while maintaining a desired level of vacuum for the completion of a procedure. The function of the throttle valve is to control the pressure in a vacuum chamber by adjusting vanes to restrict and allow the evacuation of a process gas. An interlock ensures that the gate must be fully open before the throttle vanes will operate.



Throttle / Isolation Valve Specifications

Standard Specifications

Materials

Valve body and mechanism	304 stainless steel
Welded bellows shaft seal	AM-350
Vanes	6061 aluminum, black anodized
Gate and bonnet seals	Viton® elastomer

Vacuum

Pressure range	1 x 10 ⁻¹⁰ mbar to 1 bar
Leak rate	< 1 x 10 ⁻¹⁰ mbar l/sec
Differential pressure on gate	1 atmosphere
Maximum pressure before opening	≤ 27 mbar

Temperature

Operating range	0° to 100°C
Bakeout, max.	150°C

Mechanism

Air service	80 psig
Solenoid	120 VAC 50/60 Hz or 24 VDC
Position indication is displayed on valve controller front panel	page 119
Open/close time, minimum	3 sec
Cycles until service, application dependent	1,000,000

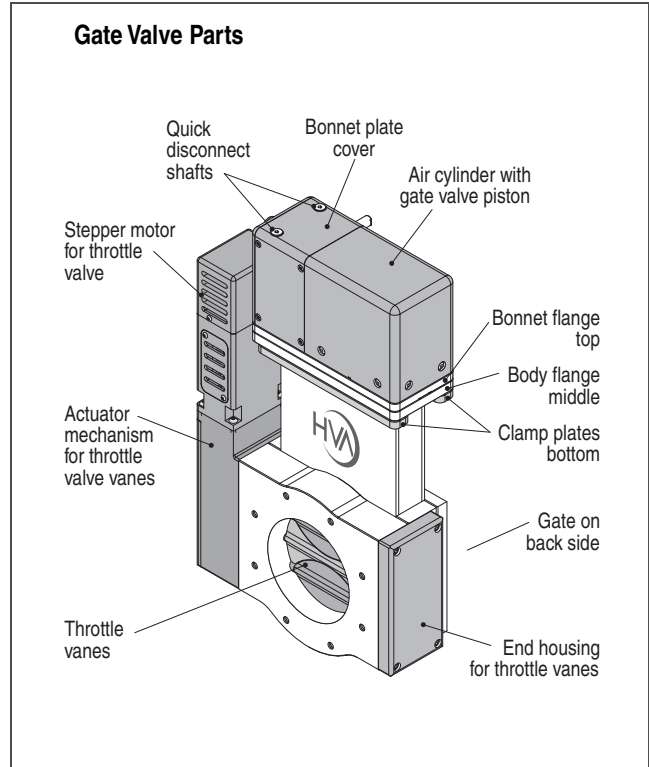

Notes

- Dimensions given in U.S. System and [metric]
- Conductance ratings based on air, given in liters per second
- Due to ongoing product development, prices, dimensions and specifications subject to change without notice

Options

All 47200 Series Valves may be equipped with alternative flanges, solenoids and seals. Contact HVA to discuss your requirements.

- Alternate voltage controls
- Latching type solenoid
- Alternate bellows materials
- Custom flanges
- Gauge ports
- Stepper motor actuator
- Roughing ports
- High temperature components, including O-rings, microswitches and actuator
- Stainless steel construction

Theory of Operation

The function of the throttle valve is to control the pressure in a vacuum chamber by adjusting vanes to restrict and allow the evacuation of a process gas. An interlock ensures that the gate must be fully open before the throttle vanes will operate.

The TVC-2000-2 controllers maintain pressure by either of two options called setpoints: pressure control setpoints or angle control setpoints.

- **Pressure control setpoints** utilize a closed loop feedback from a capacitance manometer to adjust throttle vanes with a stepper motor actuator mechanism. There are up to six user defined pressure control setpoints, displayed in a choice of pressure units.
- **Angle control setpoints** are defined by the user usually after empirical studies of the vacuum process. There are up to six user defined angle control setpoints, displayed in angular degrees.

The three figures are examples of three of the six user defined angle control setpoints, at 0°, 45° and 90°.

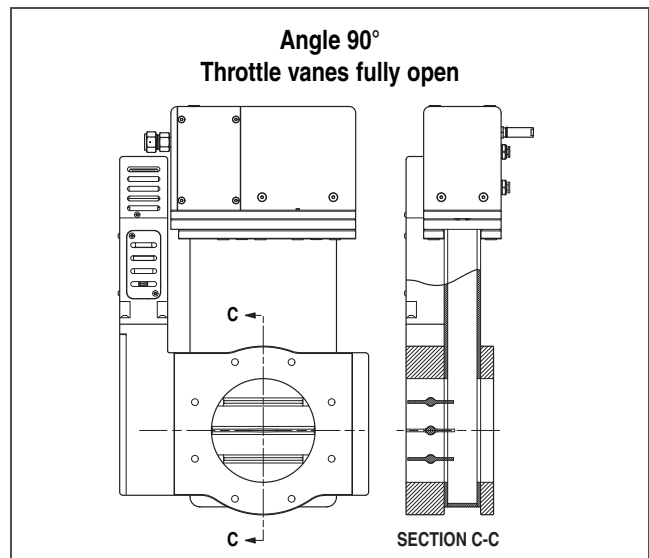
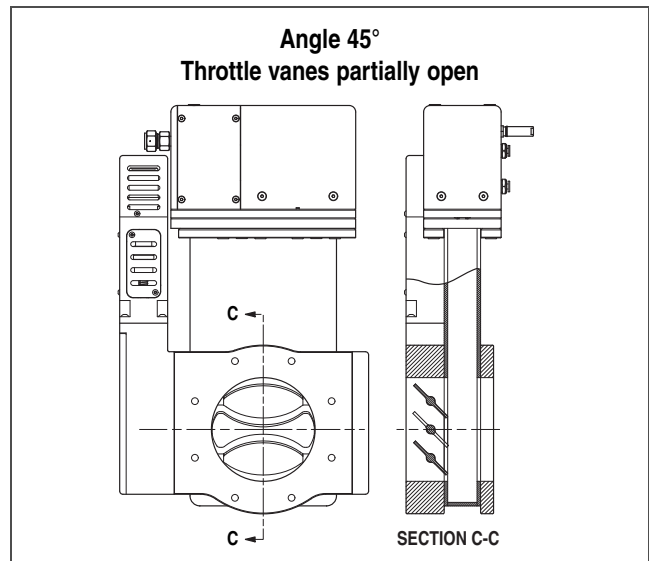
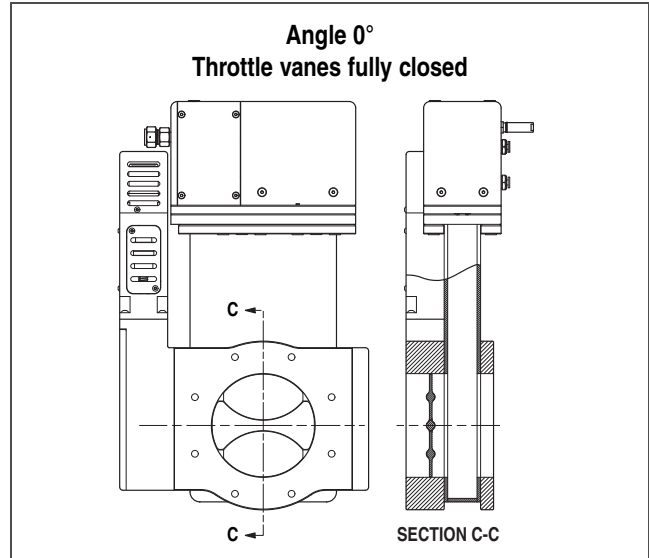



Throttle / Isolation Valves 100-mm 4.0-inch

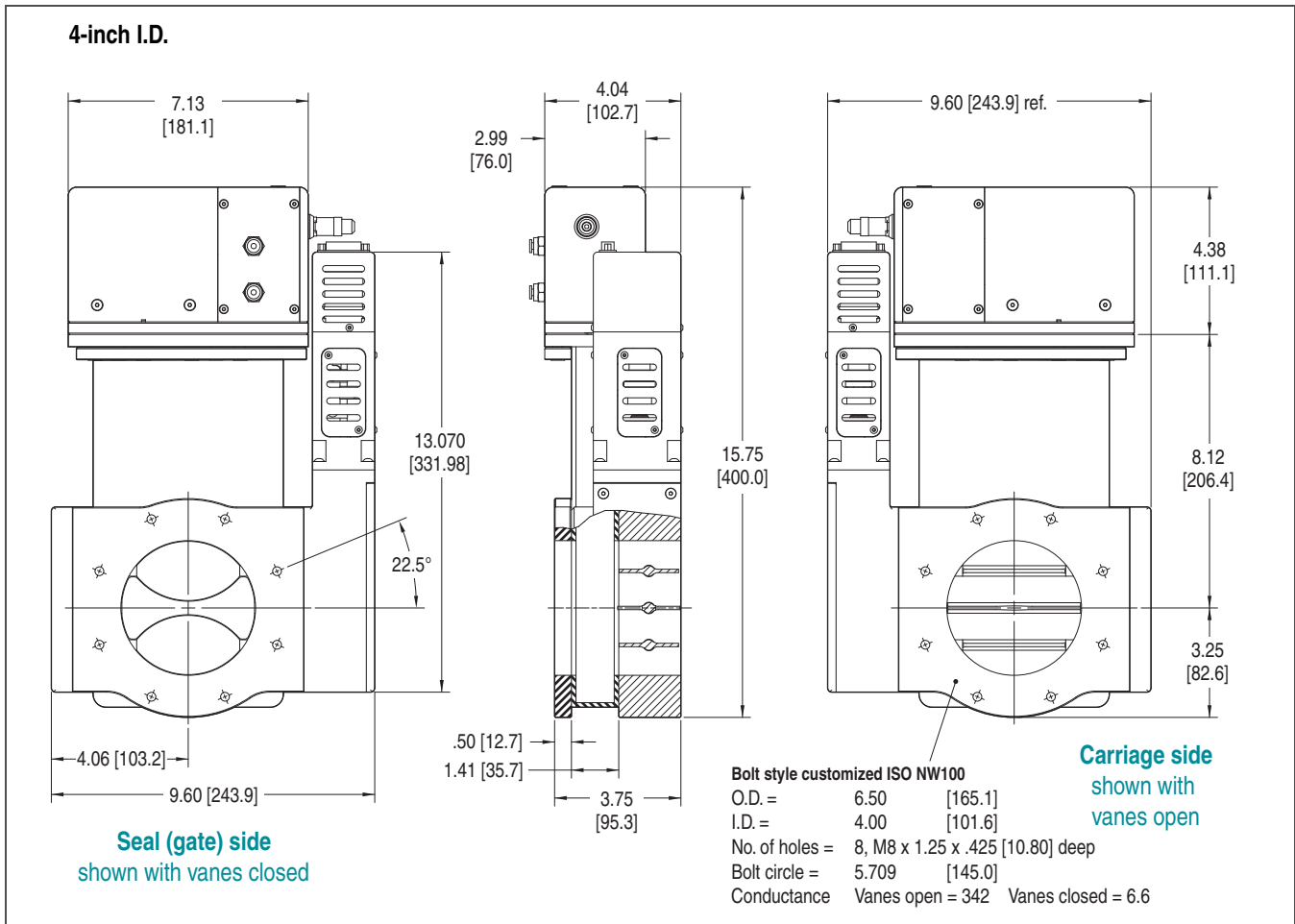

Throttle / Isolation

ISO-100 Flanges			100-mm 4.0-inch
Bonnet-Gate	Flange Type	Ship Wt lbs [kg]	Model Number *
Pneumatic			
Viton-Viton	Metric bolt	53 [24]	47212-0403R

* R = Reed switch, standard
 M = Microswitch, optional

Throttle / Isolation Valves 150-mm 6.0-inch

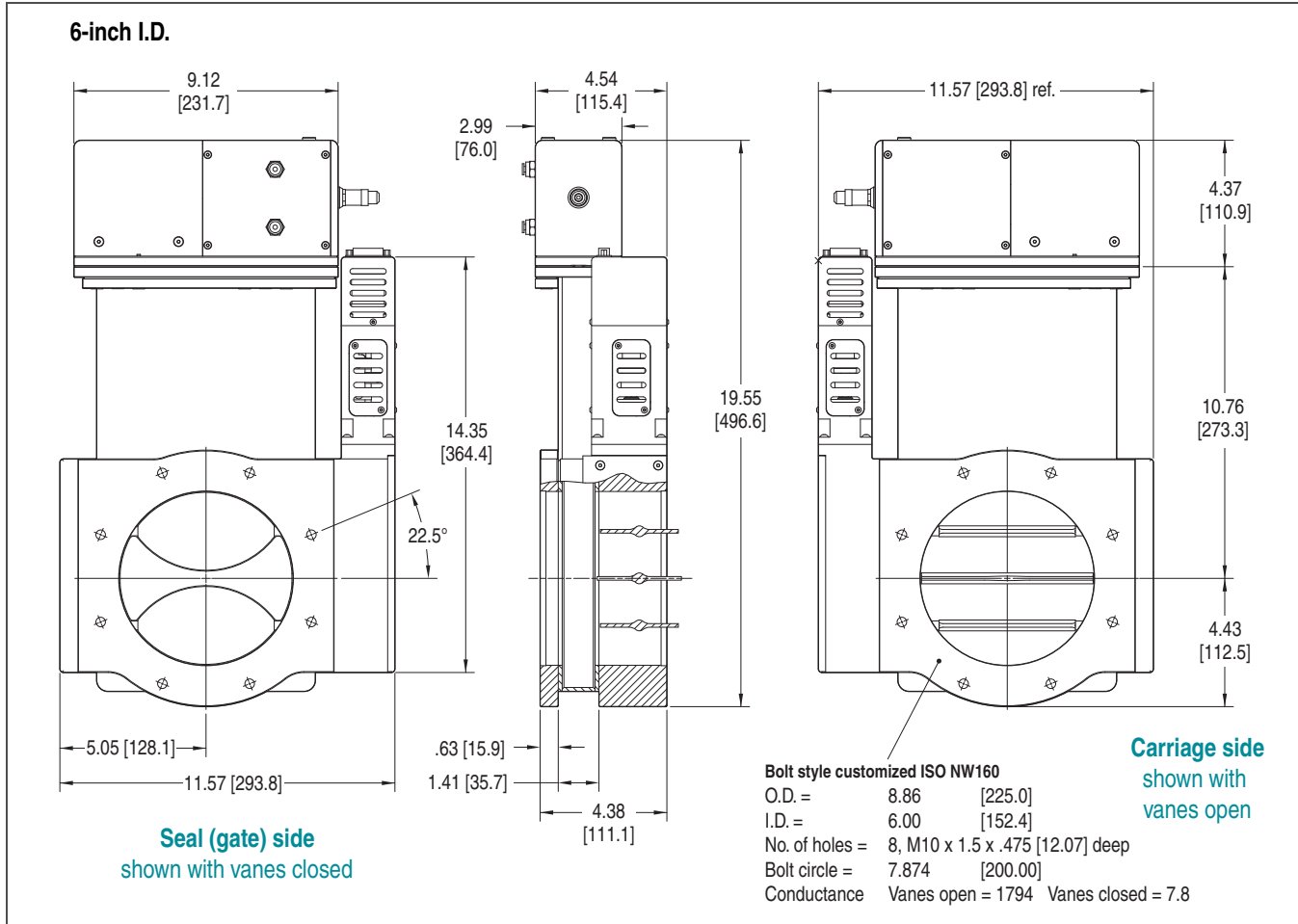

Throttle / Isolation

ISO-160 Flanges			150-mm 6.0-inch
Bonnet-Gate	Flange Type	Ship Wt lbs [kg]	Model Number *
Pneumatic			
Viton-Viton	Metric bolt	71 [32]	47212-0603R

* R = Reed switch, standard
 M = Microswitch, optional



Throttle / Isolation Valves 200-mm 8.0-inch

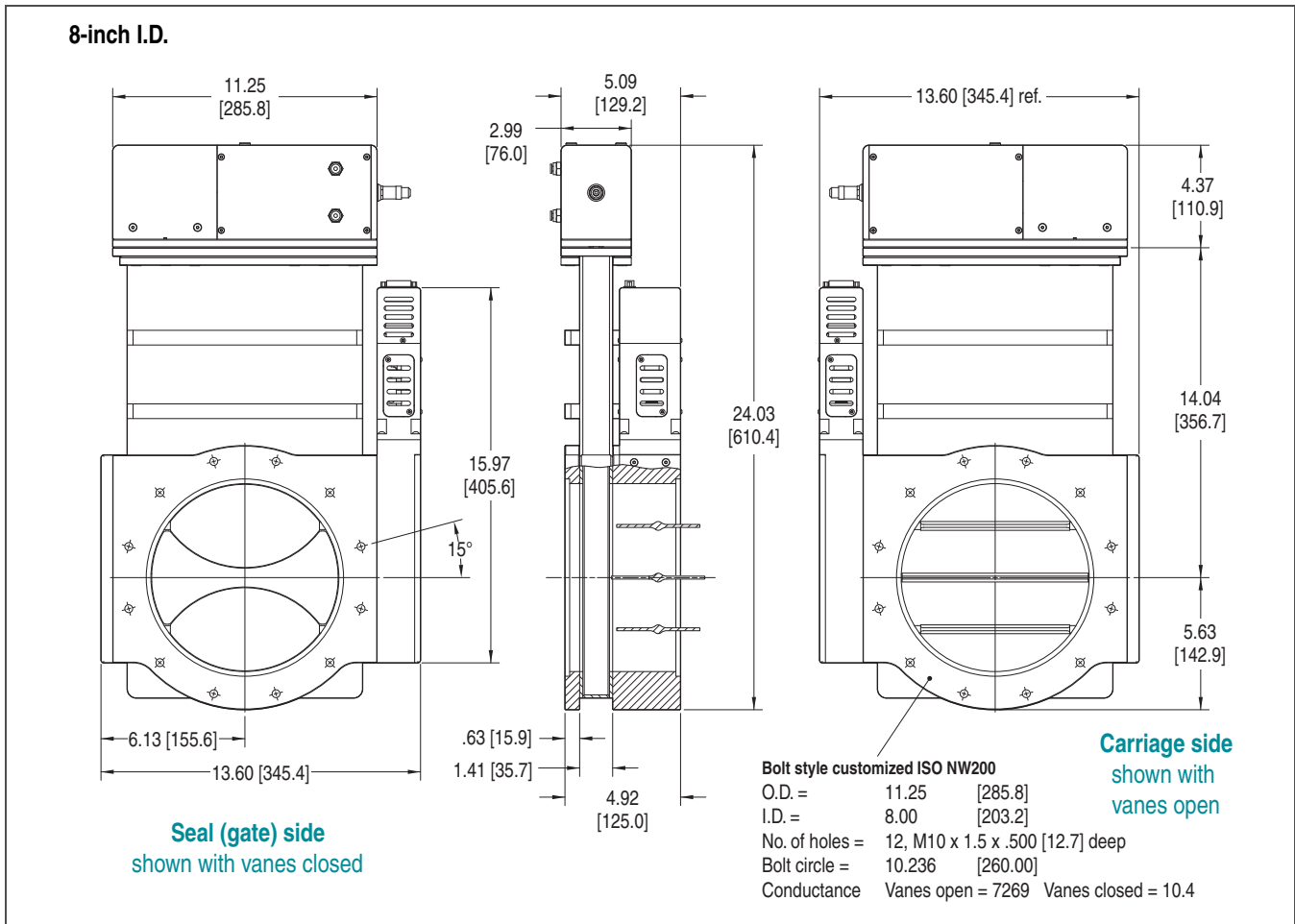

Throttle / Isolation

ISO-200 Flanges			200-mm 8.0-inch
Bonnet-Gate	Flange Type	Ship Wt lbs [kg]	Model Number *
Pneumatic			
Viton-Viton	Metric bolt	90 [41]	47212-0803R

* R = Reed switch, standard
 M = Microswitch, optional

Throttle / Isolation Valves 250-mm 10.0-inch



10-inch I.D.

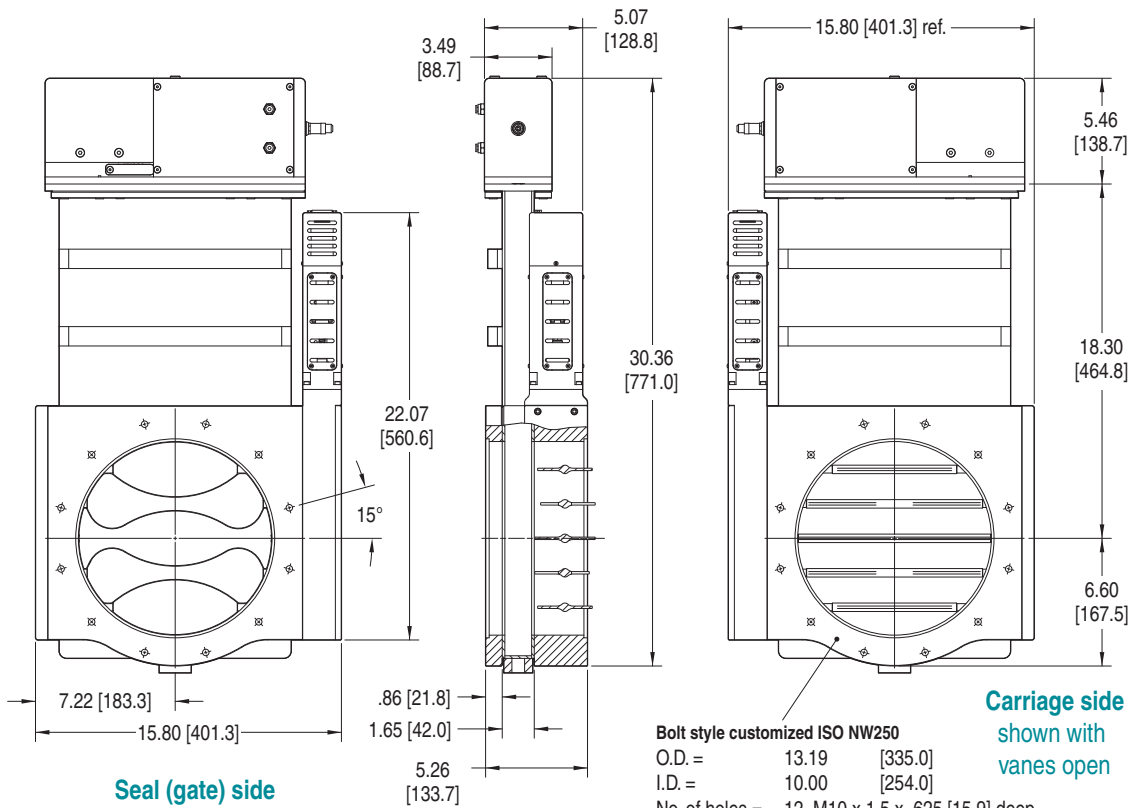

Bolt style customized ISO NW250
 O.D. = 13.19 [335.0]
 I.D. = 10.00 [254.0]
 No. of holes = 12, M10 x 1.5 x .625 [15.9] deep
 Bolt circle = 12.205 [310.0]
 Conductance Vanes open = 10312 Vanes closed = 13.0

Throttle / Isolation

ISO-250 Flanges			250-mm 10.0-inch
Bonnet-Gate	Flange Type	Ship Wt lbs [kg]	Model Number *
Pneumatic			
Viton-Viton	Metric bolt	175 [80]	47212-1003R

* R = Reed switch, standard
 M = Microswitch, optional



Throttle / Isolation Valves 300-mm 12.0-inch

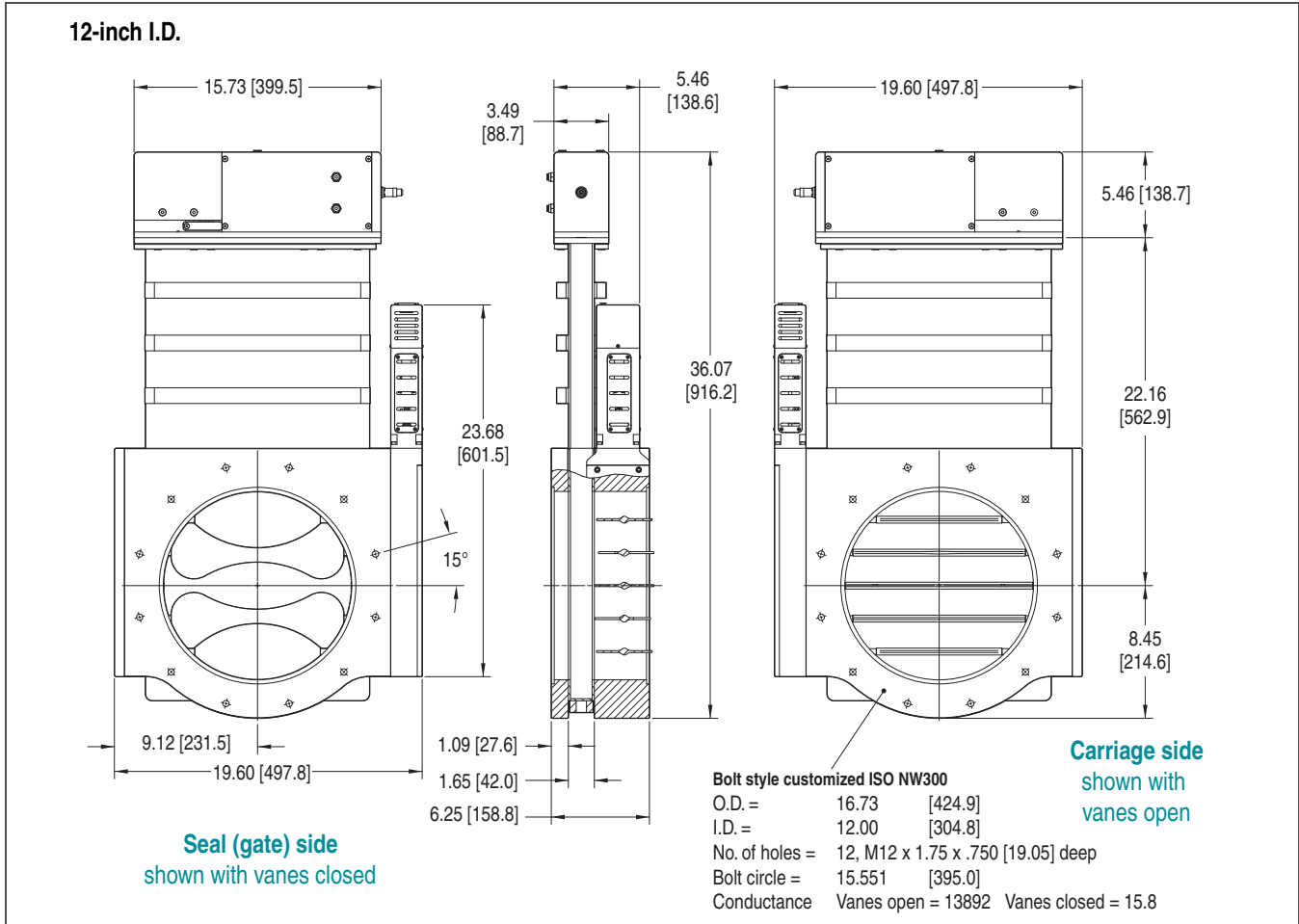

Throttle / Isolation

ISO-300 Flanges			300-mm 12.0-inch
Bonnet-Gate	Flange Type	Ship Wt lbs [kg]	Model Number *
Pneumatic			
Viton-Viton	Metric bolt	265 [120]	47212-1203R

* R = Reed switch, standard
 M = Microswitch, optional

Throttle / Isolation Valves 350-mm 14.0-inch



14-inch I.D.

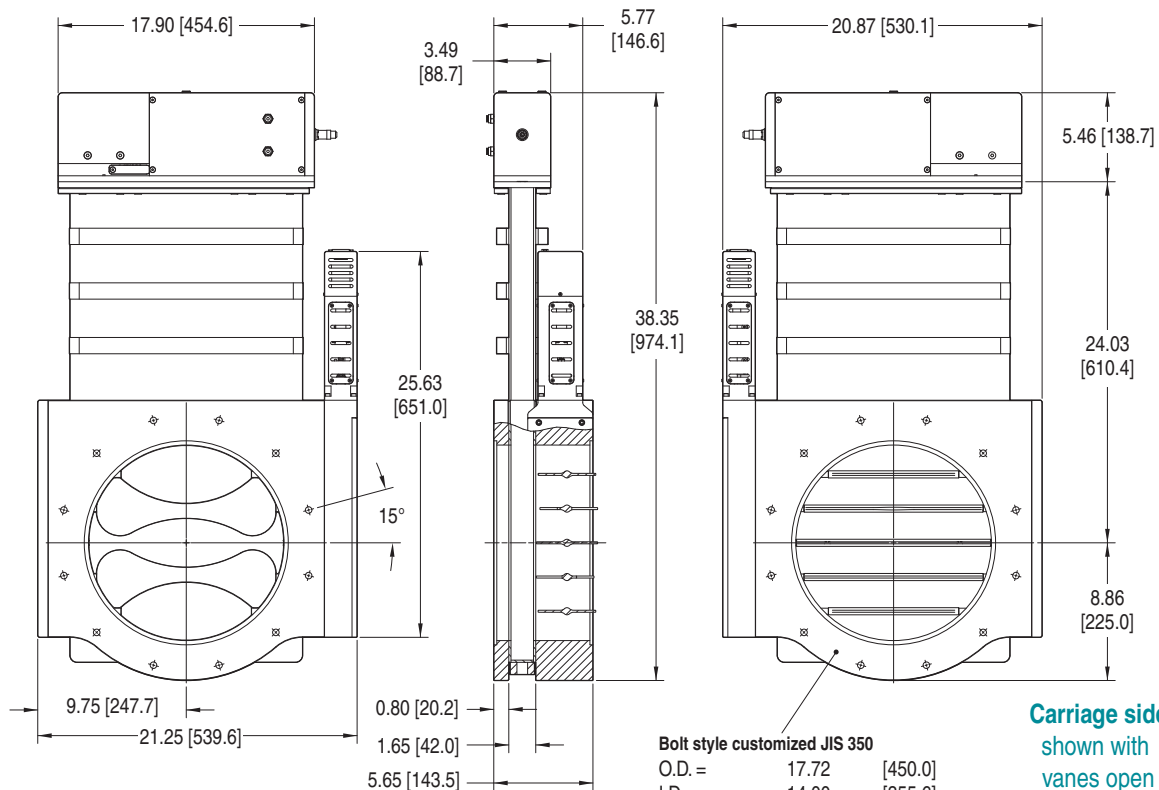

Bolt style customized JIS 350
 O.D. = 17.72 [450.0]
 I.D. = 14.00 [355.6]
 No. of holes = 12, M12 x 1.75 x .625 [15.88] deep
 Bolt circle = 16.535 [420.0]
 Conductance Vanes open = 17558 Vanes closed = 18.7

Throttle / Isolation

JIS G 14.0 Flanges			350-mm 14.0-inch
Bonnet-Gate	Flange Type	Ship Wt lbs [kg]	Model Number *
Pneumatic			
Viton-Viton	Metric bolt	360 [165]	47212-1405R

* R = Reed switch, standard
 M = Microswitch, optional



Throttle Valve Controller Introduction

Description

The Throttle Valve Controller has six programmable pressure setpoints and six programmable angle setpoints. The vacuum range can be programmed manually or through HVA programming software via RS232 communication port.

Using seven front panel buttons and a vacuum fluorescent display, the user may set values for each of the programmable setpoints, and then may select which setpoint to use for the current vacuum process in operation. Models available for one or two manometers. The controller uses information from the capacitance manometer to display pressure values. The display is updated every two seconds, but internally the pressure and angle are updated five times per second. Prices available on request.

Applications

The TVC-2000-2 controllers may be used to control any compatible throttle valve. They have been designed for and are fully integrated with the HVA 47200 Series of Throttle/Isolation Gate Valves.



Product Features

- Front panel or computer interface control
- Six programmable pressure points
- Six programmable vane angle points

Throttle /
Isolation

Throttle Valve Controller Specifications

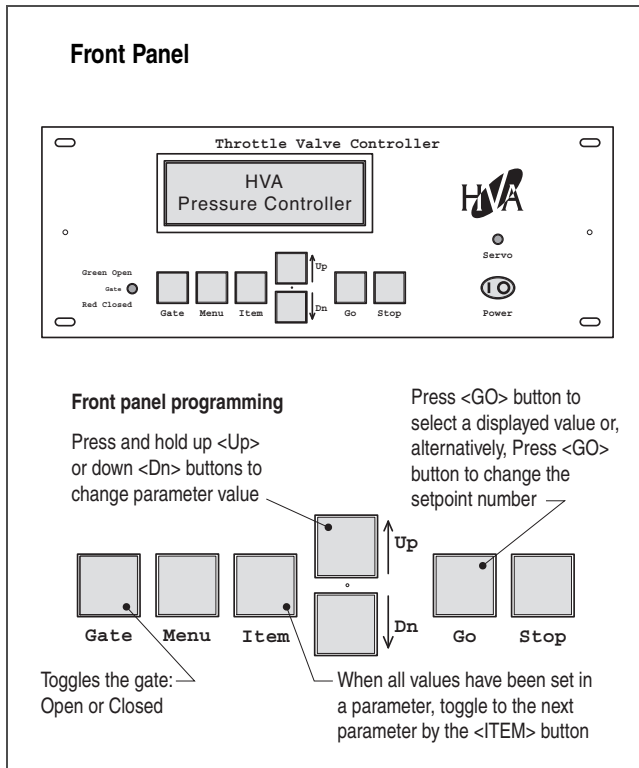

Notes

- Dimensions given in U.S. System and [metric]
- Due to ongoing product development, prices, dimensions and specifications subject to change without notice

Cable Sets ~ Please contact us to discuss your requirements.

AC power cord 8-foot, 3-pin
Stepper Motor cable 10-foot, 15-pin Female Type-D

Model TVC-CS-8

AC power cord, Stepper Motor cable and two (2) 15-pin Male Type-D connectors only for manometers

Note: Type-D mating connectors for manometers only, cables not included.

Standard Specifications

Materials

Chassis Aluminum
Display Vacuum Fluorescent Display

Size

Standard electronics cabinet half-rack size
Front panel 9.5 W x 3.5 H x 0.125 Thk
Chassis 8.0 W x 3.5 H x 10.5 Deep

Input Power

65 Watts, maximum
85 to 250 VAC Auto switching
Supplied fuse rating for 120 VAC operation 250 V, 700 mA
Recommended fuse rating for 220 VAC operation* 250 V, 400 mA

Weight

TVC-2000-2 4 lbs (1.8 kg)

Programming

6 programmable angle points 0° to 90°
6 programmable pressure points Dependent on manometer

Vacuum range Typically <10 Torr

Manometers, customer supplied

Excitation voltages ±15 volt
Output signal 0–10 volts
Connection 15-pin D connector

*The supplied fuse provides dead short protection of the power supply for the full range of input voltage. However, it is recommended that for the higher input voltages, the fuse be replaced to match the corresponding lower currents.



Chassis dimensions

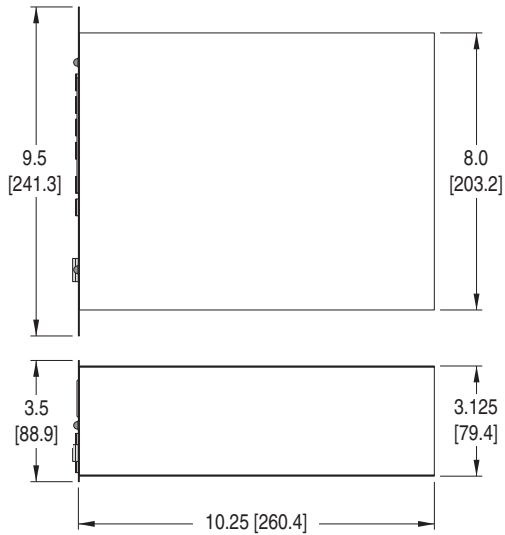

All dimensions given in inches [mm].

Throttle Valve Controller

Input Power	Output Signal	Ship Wt lbs [kg]	Model Number
Auto switching			
85-250 VAC	0-10 Volts	5 [2]	TVC-2000-2
Cable set			
AC power cord, Stepper Motor cable and two (2) 15-pin Male Type-D connectors (no cables)		2 [1]	TVC-CS-8

Rear panel

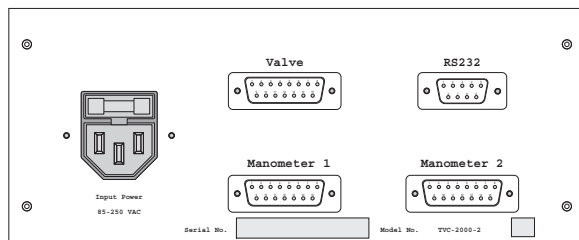

Throttle / Isolation



Throttle/Isolation

Throttle/Isolation Valves
47200 Series

End of Section

