

# Closed-Loop

## Closed-Loop Throttle Valves **21800 Series**

Introduction	Page 98
Specifications	Page 99
Theory of Operation	Page 100
100-mm      4.0-inch	Page 101
150-mm      6.0-inch	Page 102
200-mm      8.0-inch	Page 103
250-mm      10.0-inch	Page 104
300-mm      12.0-inch	Page 105
ANSI, JIS & Custom	Page 106





Closed-  
Loop  
Throttle

## Product Features

- ❑ Patented Throttle Actuating Mechanism that is infinitely variable from fully open to fully closed
- ❑ Stainless steel welded bellows
- ❑ Standard or custom flange options
- ❑ 1,000,000 cycles before servicing (application dependent)

## Description

The 21800 Series Closed-Loop Pneumatic Throttle Gate Valves utilize a standard HVA 21200 Series valve design with the addition of a patented throttle actuating mechanism. The throttle actuating mechanism consists of an MKS 146C Vacuum Gauge Measurement and Control System, an OMRON Analog Fiber-Optic Sensor and Amplifier, a PNEUTRONICS Pressure Control Unit and an over-sized HVA patented differential pressure actuator assembly. Shock and vibration are reduced to a minimum by our unique air cylinder design. There are no mechanical locks inside the vacuum which is extremely beneficial for semiconductor and sensitive processes requiring vibration-free operation. All moving joints have hardened shafts, reducing particulate generation and providing smooth actuation.

The system operates in a closed control loop by monitoring either the valve's True Position or the system Pressure/Conductance. In the Pressure/Conductance Mode the valve is opened or closed until the desired system gas flow is achieved as monitored by the MKS flow or pressure gauges. The MKS controller can monitor two gauges in addition to controlling the valve. In the True Position Mode the position of the valve actuator piston is monitored by the OMRON sensor. The sensor signal is sent to the MKS controller which then sends a signal corresponding to the desired valve position to the PNEUTRONICS pressure control unit. The pressure control unit controls the differential pressure applied to the actuator piston to move it in the desired direction.

## Applications

The HVA stainless steel body offers one of the smallest interior surface areas in the vacuum valve industry. The body and all major internal components are vacuum furnace brazed at 1100° C at  $1 \times 10^{-6}$  Torr, ensuring maximum joint integrity. This eliminates the possibility of virtual leaks or entrapment areas and minimizes body distortion found in conventionally welded valves. For maintenance purposes, the carriage assembly can be removed from the body without removing the valve from the system. These valves can be used with cryopumps, turbomolecular pumps or in any applications requiring clean, high cycle, low maintenance and low outgassing valves with positive shutoff characteristics. Available in standard CF-F, KF, ISO or ANSI flange configurations, as well as optional JIS or custom configurations.



# Closed-Loop Throttle Valves Specifications

## Standard Specifications

### Materials

Valve body and mechanism	304 stainless steel
Welded bellows shaft seal	AM-350
Bonnet / gate seals	
HV	Viton® elastomer
UHV	OFHC copper / Viton® elastomer

### Vacuum

Pressure range	
HV	1 x 10 <sup>-9</sup> Torr
UHV	1 x 10 <sup>-10</sup> Torr
Leak rate	2 x 10 <sup>-10</sup> AtmCC/Sec
Differential pressure	760 Torr in either direction
Maximum Δ pressure before opening	20 Torr

### Bakeout Temperature

	without solenoid
Elastomer sealed bonnet	150°C
Actuator	60°C

### Mechanism

Air service	80 psig
MKS Controller	150 Watts
Power requirements	85–135 VAC or 180–270 VAC 50/60 Hz
Position or flow indication	MKS Controller front panel display

### Pneumatic Data

Minimum pneumatic output volume	1 cubic inch
Output range	0–80 PSIG
Operating range	0–80 PSIG
Maximum supply pressure	80 PSIG
Pressure linearity	6% FS maximum
Pneumatic connection	1/4" O.D. tubing
Pressure accuracy (Variable Pressure Solenoid Valve)	1.5% FS maximum

### Power Requirement and Logic

Main Power	120/230 VAC
Current requirement	Max 400 milliamperes
Input control signal	4–20 MADC
Input impedance	250 ohms
Electrical plug-in connector for #28 to 14 AWG wire service	

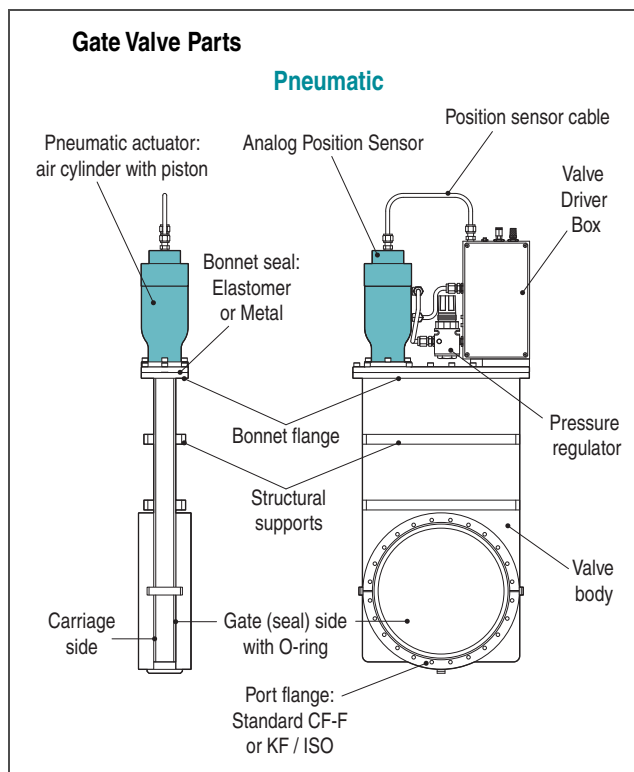

### Notes

- Dimensions given in U.S. System and [metric]
- Conductance ratings based on air, given in liters per second
- Due to ongoing product development, prices, dimensions and specifications subject to change without notice

### Options

All 21800 Series Valves may be equipped with alternative flanges, solenoids and seals. Contact HVA to discuss your requirements.

- Alternate voltage controls
- JIS configurations
- Custom flange sizes
- Roughing ports
- Metal sealed bonnet
- High temperature components, including O-rings, microswitches and actuator
- Custom materials, such as Inconel® or Kalrez®
- Bakeout jacket with or without regulators

Closed-Loop Throttle

## Theory of Operation

The Closed-Loop Pneumatic Throttle Valve is designed to provide the user the means to either control the pressure in a process chamber or vary the position of the valve's gate to change the conductance through the valve in a closed loop fashion.

The valve's gate position is controlled by the HVA patented actuator. The variance of the position is primarily controlled by creating or disturbing the equilibrium of the two volumes in the air cylinder that are separated by the piston. A 4–20 mA analog sensor is incorporated in the actuator mechanism to provide a signal that represents the precise position of the valve. While in the position control mode, this sensor provides the signal loop to the controller that is required to position the valve. While in the pressure control mode, a pressure transducer is utilized to provide that loop, and the position sensor becomes a real-time position indicator. This approach provides precise pressure or conductance control without sacrificing the positive shutoff feature so that the valve closes and seals in the event of power loss in the system.

Refer to the Throttle Valve Schematic below.

1. The Closed-Loop Throttle Valve utilizes a standard HVA gate valve design with the exception of a patented throttle actuating mechanism assembly. The throttle actuator incorporates an air spring design via a pressure regulator that is mounted on the top

fitting of the air cylinder. Its function is to close and seal the valve in the event of electric power loss to the system. This eliminates the need for a secondary normally closed isolation valve.

2. The Analog Position Sensor is mounted on top of the air cylinder. Its function is to provide the controller a 4–20 mA signal that varies in accordance with any change in the piston position. This signal can be used to close the loop on the position of the gate whenever desired or to indicate the position while controlling the pressure control mode.

3. The Valve Driver Box contains the air logic circuitry, the power connections and the electrical signals that are required to interface between the controller and the valve. It incorporates the following components:

- Variable Pressure Solenoid Valve: The function of this valve is to vary its output pressure between 5 and 80 PSIG in proportion to the 4–20 mA signal that it receives from the controller. This variance in pressure will cause the valve to move towards the open, closed, or the hold position of the throttle valve's gate.
- Pressure Regulator: The function of this part is to reduce its input pressure from 80 PSIG to 40 PSIG.
- Fiber Optic Amplifier: The amplifier relays the position of the piston to the MKS Controller.

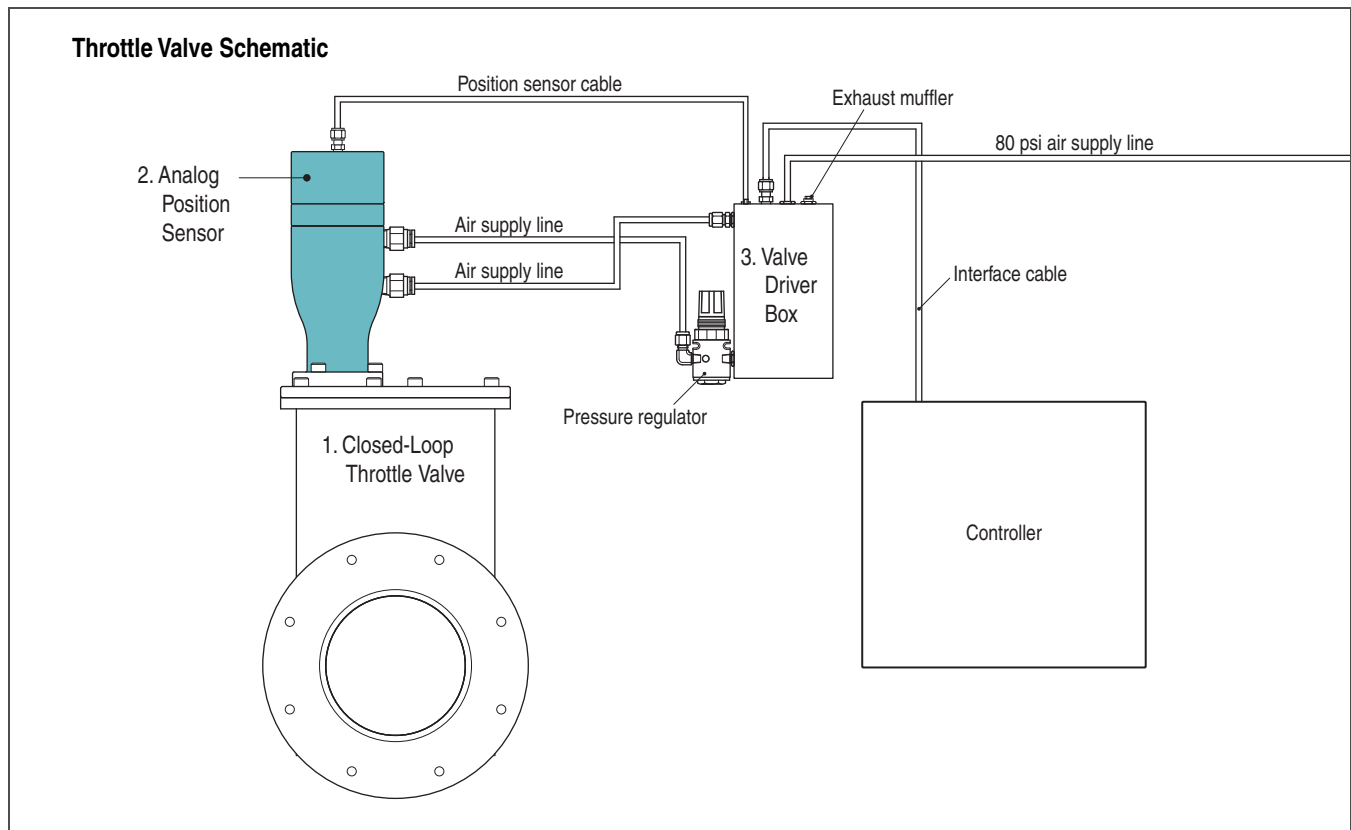



# Closed-Loop Throttle Valves 100-mm 4.0-inch

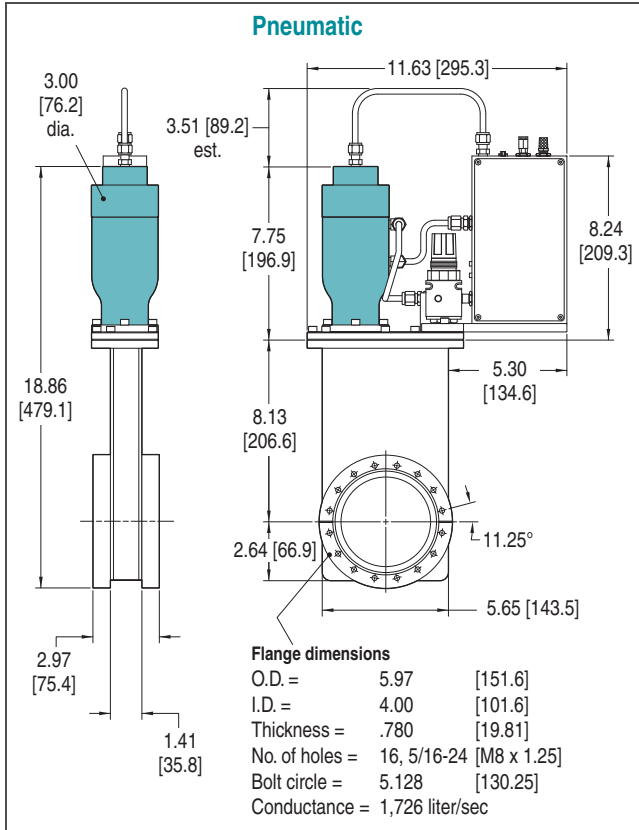

CF-F 6.00 Flanges			100-mm 4.0-inch
Bonnet-Gate	Flange Type	Ship Wt lbs [kg]	Model Number
<b>Pneumatic</b>			
Viton-Viton	U.S. Bolt	33 [15]	21810-0400

For metric flanges, replace last 0 in Model Number with 4

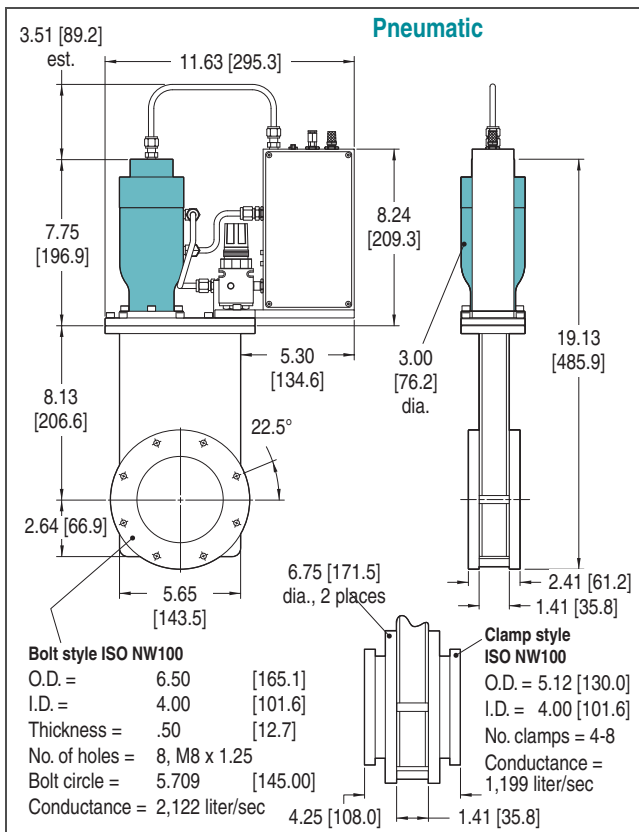

ISO-100 Flanges			100-mm 4.0-inch
Bonnet-Gate	Flange Type	Ship Wt lbs [kg]	Model Number
<b>Pneumatic</b>			
Viton-Viton	Metric bolt	33 [15]	21810-0403
Viton-Viton	Clamp	43 [20]	21810-0406

Closed-Loop Throttle

# Closed-Loop Throttle Gate Valves 150-mm 6.0-inch

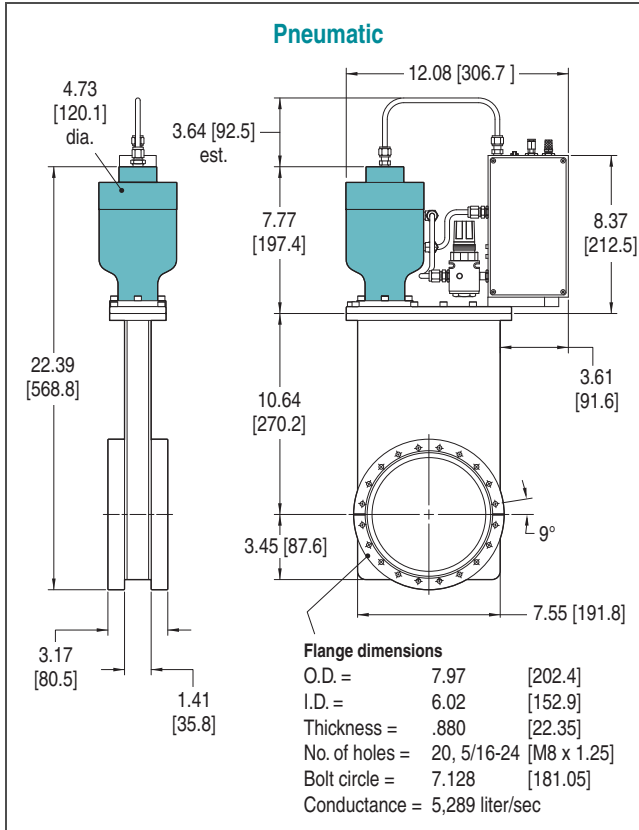

CF-F 8.00 Flanges			150-mm 6.0-inch
Bonnet-Gate	Flange Type	Ship Wt lbs [kg]	Model Number
<b>Pneumatic</b>			
Viton-Viton	U.S. Bolt	50 [23]	21810-0600

For metric flanges, replace last 0 in Model Number with 4

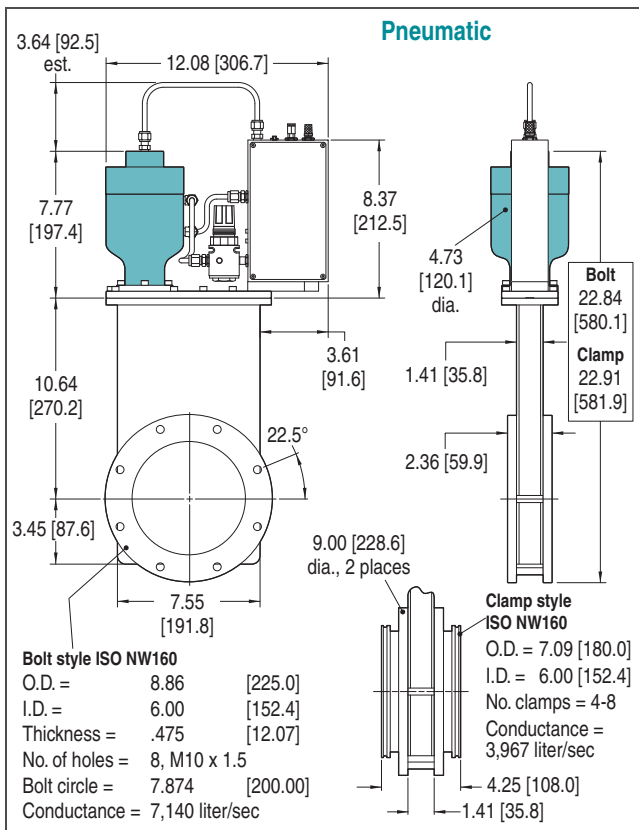

ISO-160 Flanges			150-mm 6.0-inch
Bonnet-Gate	Flange Type	Ship Wt lbs [kg]	Model Number
<b>Pneumatic</b>			
Viton-Viton	Metric bolt	50 [23]	21810-0603
Viton-Viton	Clamp	70 [32]	21810-0606



# Closed-Loop Throttle Valves 200-mm 8.0-inch

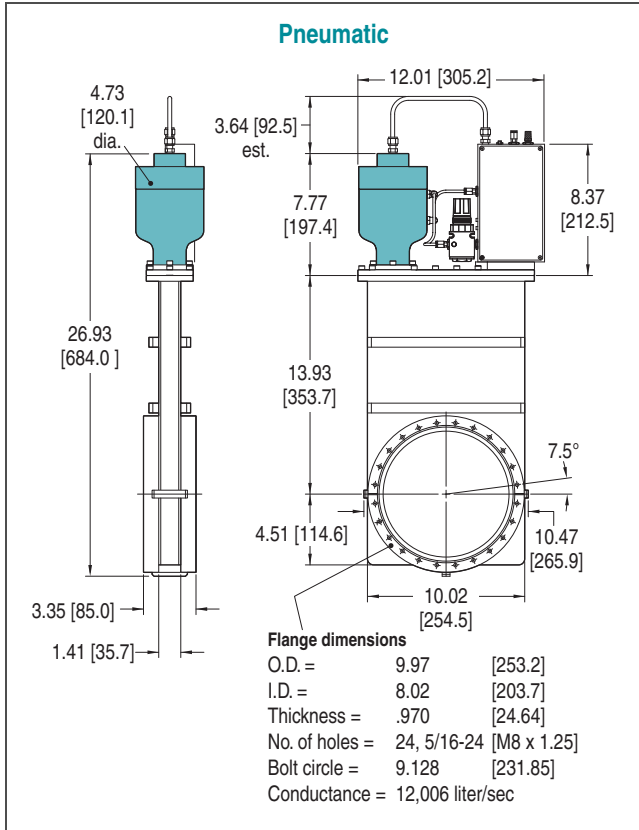

CF-F 10.00 Flanges			200-mm 8.0-inch
Bonnet-Gate	Flange Type	Ship Wt lbs [kg]	Model Number
<b>Pneumatic</b>			
Viton-Viton	U.S. Bolt	75 [34]	21810-0800

For metric flanges, replace last 0 in Model Number with 4

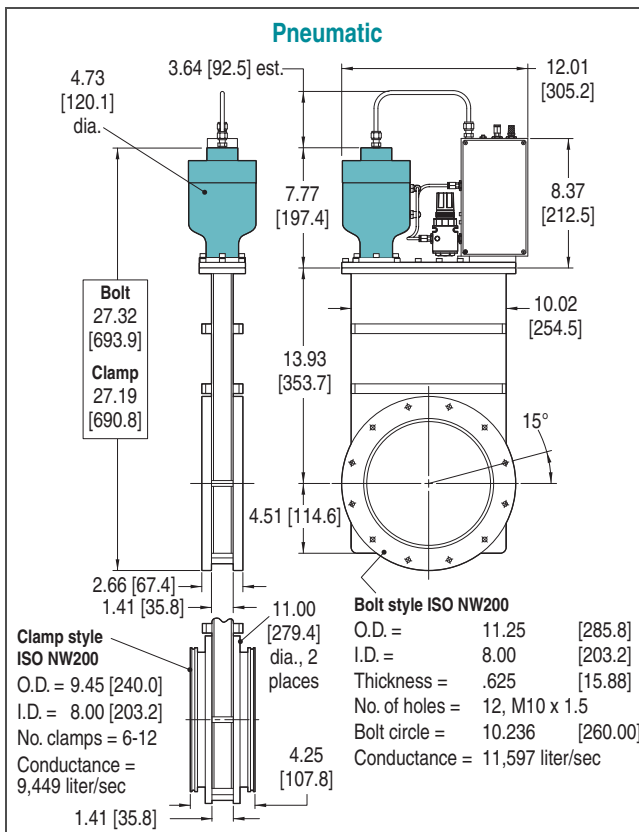

ISO-200 Flanges			200-mm 8.0-inch
Bonnet-Gate	Flange Type	Ship Wt lbs [kg]	Model Number
<b>Pneumatic</b>			
Viton-Viton	Metric bolt	75 [34]	21810-0803
Viton-Viton	Clamp	95 [43]	21810-0806

Closed-Loop Throttle

# Closed-Loop Throttle Gate Valves 250-mm 10.0-inch

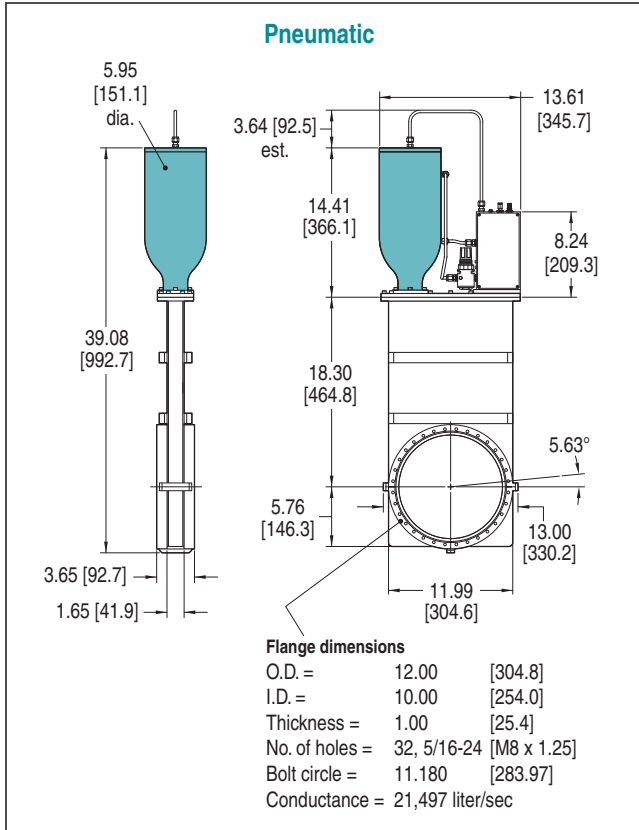

CF-F 12.00 Flanges		250-mm 10.0-inch	
Bonnet-Gate	Flange Type	Ship Wt lbs [kg]	Model Number
<b>Pneumatic</b>			
Viton-Viton	U.S. Bolt	147 [67]	21810-1000

For metric flanges, replace last 0 in Model Number with 4

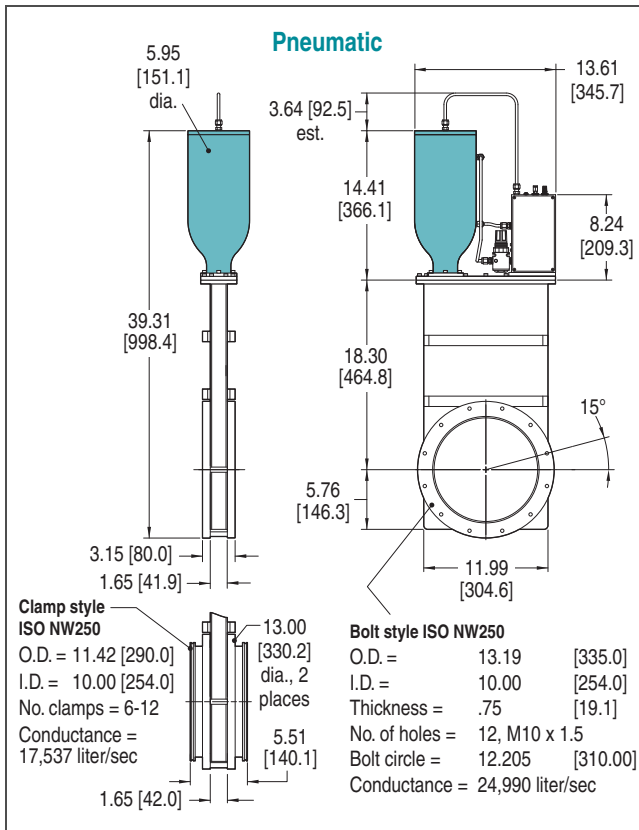

ISO-250 Flanges		250-mm 10.0-inch	
Bonnet-Gate	Flange Type	Ship Wt lbs [kg]	Model Number
<b>Pneumatic</b>			
Viton-Viton	Metric bolt	160 [73]	21810-1003
Viton-Viton	Clamp	190 [86]	21810-1006



# Closed-Loop Throttle Valves 300-mm 12.0-inch

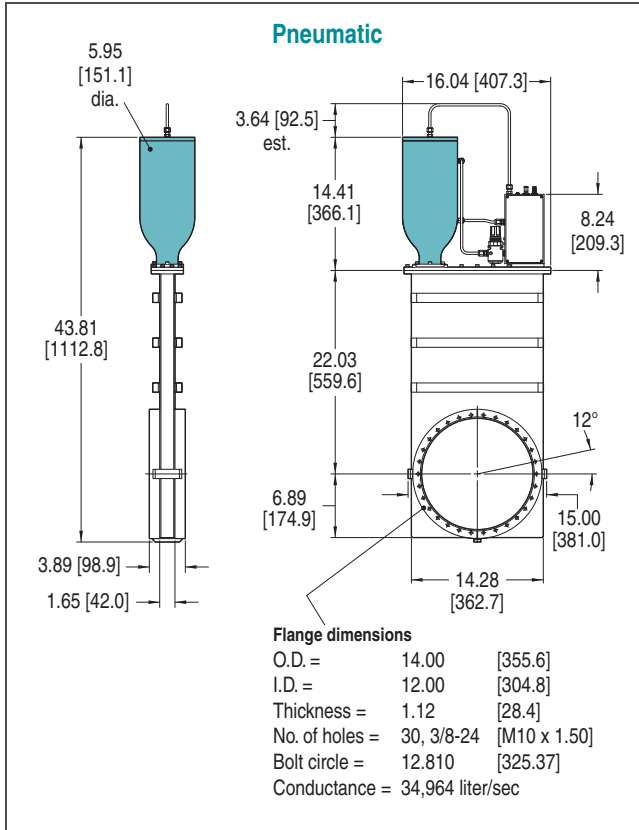

CF-F 14.00 Flanges		300-mm 12.0-inch	
Bonnet-Gate	Flange Type	Ship Wt lbs [kg]	Model Number
<b>Pneumatic</b>			
Viton-Viton	U.S. Bolt	170 [77]	21810-1200

For metric flanges, replace last 0 in Model Number with 4

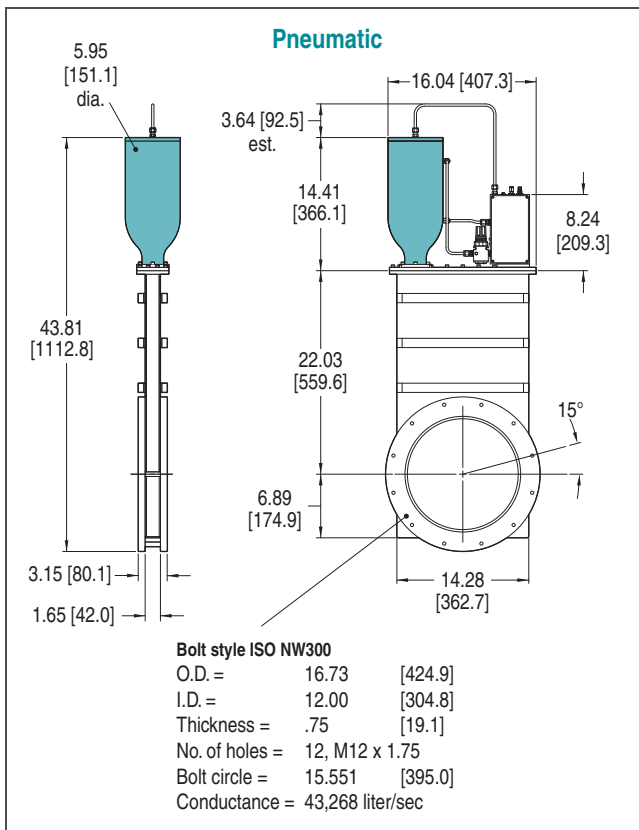

ISO-300 Flanges		300-mm 12.0-inch	
Bonnet-Gate	Flange Type	Ship Wt lbs [kg]	Model Number
<b>Pneumatic</b>			
Viton-Viton	Metric bolt	170 [77]	21810-1203

Closed-Loop Throttle

## ANSI Flange Models

ANSI Models are designed for high vacuum applications specifically when pressure ranges approximate  $1 \times 10^{-9}$  Torr and bakeout temperatures do not exceed 200°C. Both the bonnet and gate seals come standard with Viton® elastomer O-rings.

These valves provide valving for cryopumps, turbomolecular pumps, ion pumps, and other applications requiring clean, low out-gassing valves.

Pneumatic valves are supplied with 120 VAC solenoid and a Reed switch position indicator.

Standard flanges are smooth faced, non-rotatable and threaded. When O-ring grooves are required on flanges, please specify one

of the following options:

- O-ring groove on gate side only
- O-ring groove on carriage side only
- O-ring grooves on both gate side and carriage side

O-ring groove I.D. is 0.250-inch larger than the valve I.D. Flange O-rings are not included with the valve, and may be purchased separately.

## JIS & Custom Flange Models

Installations requiring JIS flanges may be obtained through HVA. Additionally, non-standard installations requiring other specialty flanges may be custom ordered through HVA. Contact HVA to dis-

## ANSI Flange Dimensions

MM	Inch	Flange Size	Conductance liter/sec air	No. Holes	Thread	B.C. mm	B.C. inch	O.D. mm	O.D. inch	I.D. mm	I.D. inch
100	4.0	4.0 ANSI	2,122	8	3/8-16	190	7.50	229	9.00	102	4.00
150	6.0	6.0 ANSI	7,023	8	3/4-10	241	9.50	279	11.00	152	6.00
200	8.0	6.0 ANSI	14,374	8	3/4-10	241	9.50	279	11.00	203	8.00
200	8.0	8.0 ANSI	14,374	8	3/4-10	298	11.75	343	13.50	203	8.00
250	10.0	10.0 ANSI	24,990	12	3/4-10	362	14.25	406	16.00	254	10.00
300	12.0	10.0 ANSI	43,268	12	3/4-10	362	14.25	406	16.00	305	12.00
300	12.0	12.0 ANSI	43,268	12	3/4-10	432	17.00	483	19.00	305	12.00

## ANSI Valve Dimensions

Nom. I.D.	A	B	C	D	E	F	G	H	K	L
100 mm	67	207	61	76	209	197	89	518	144	295
4.0 in	2.64	8.13	2.41	3.00	8.24	7.75	3.51	20.40	5.65	11.63
150 mm	88	270	61	120	213	197	93	607	192	307
6.0 in	3.45	10.64	2.41	4.73	8.37	7.77	3.64	23.91	7.55	12.08
200 mm	115	354	70	120	213	197	93	691	255	305
8.0 in	4.51	13.93	2.76	4.73	8.37	7.77	3.64	27.19	10.02	12.01
200 mm	115	354	71	120	213	197	93	723	255	305
8.0 in	4.51	13.93	2.78	4.73	8.37	7.77	3.64	28.44	10.02	12.01
250 mm	146	465	80	151	209	366	93	1034	305	346
10.0 in	5.76	18.30	3.15	5.95	8.24	14.41	3.64	40.71	11.99	13.61
300 mm	175	560	80	151	209	366	93	1129	363	407
12.0 in	6.89	22.03	3.15	5.95	8.24	14.41	3.64	44.44	14.28	16.04
300 mm	175	560	80	151	209	366	93	1167	363	407
12.0 in	6.89	22.03	3.15	5.95	8.24	14.41	3.64	45.94	14.28	16.04

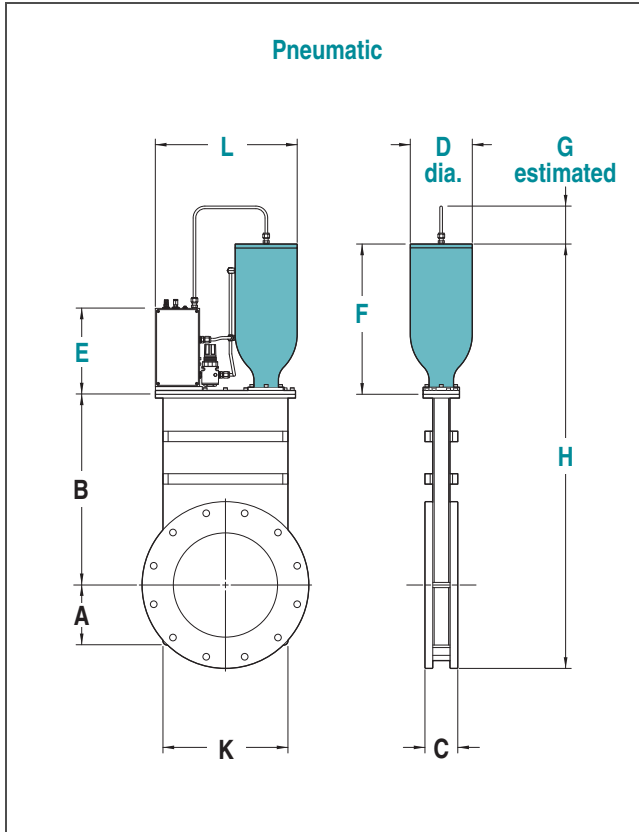

ANSI Flanges		Viton Bonnet and Gate	
Size inch [mm]	Flange Size	Ship Wt lbs [kg]	Model Number
<b>Pneumatic</b>			
4.0 [100]	4.0 ANSI	33 [15]	21810-0401
6.0 [150]	6.0 ANSI	50 [23]	21810-0601
8.0 [200]	6.0 ANSI	75 [34]	21810-0801
8.0 [200]	8.0 ANSI	75 [34]	21810-0802
10.0 [250]	10.0 ANSI	160 [72]	21810-1001
12.0 [300]	10.0 ANSI	170 [77]	21810-1201
12.0 [300]	12.0 ANSI	180 [82]	21810-1202

Closed-Loop Throttle

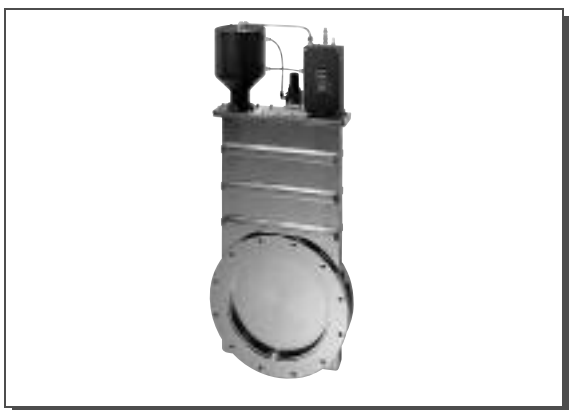

# Closed-Loop

Closed-Loop Throttle Valves  
**21800 Series**

**End of Section**

